



# User Manual

LSUM 048R6C 0166F EA YJ



# User Manual

## CONTENT

1. Overview .....	04
2. Unpacking .....	05
3. Safety .....	05
4. Identification of features .....	06
5. Module to module connection .....	07
6. Output terminal connection .....	08
7. Output connector .....	09
8. Mounting .....	11
9. Maintenance .....	12
10. Contact Information .....	13
Appendix I .....	14
Appendix II .....	17

# User Manual

LSUM 048R6C 0166F EA YJ

## 1. Overview

The LS 48.6V / 166F Ultracapacitor Module has high energy and low ESR to meet energy storage and power delivery requirements.

The cells used in the module have 2.7 V maximum voltage rating and are connected in series to get higher operating voltage of modules. To meet the long cycle life requirements, the cells operate under 2.7V. In addition, all the cells are balanced by balancing circuit connected parallel to each cell.

# User Manual

LSUM 048R6C 0166F EA YJ

## 2. Unpacking

Inspect the shipping carton for signs of damage prior to unpacking the module. Damage to the shipping carton or module should be reported to the carrier immediately.

Remove the module from the shipping carton and retain the shipping materials until the unit has been inspected and is determined to be operational.

**NOTE:** The original shipping materials are approved for both air and ground shipment. The module should be removed from the shipping carton by lifting the body of the module.

## 3. Safety



Do not operate above specified voltage.

Do not operate above specified temperature rating.

Do not touch terminals with conductors while charged. Serious burns, shock, or material fusing may occur.

Protect surrounding electrical components from incidental contact.

Provide sufficient electrical isolation when working above 48.6V DC.

Prior to installation and removal from the equipment, it is mandatory to fully discharge the module.

# User Manual

LSUM 048R6C 0166F EA YJ

## 4. Identification of features

- Product Image



<Fig. 1> Product Image

# User Manual

LSUM 048R6C 0166F EA YJ

## 5. Module to module connection

- There are series and parallel connection for High power



<Fig. 2> Series Connection of Modules



<Fig. 3> Parallel Connection of Modules.

# User Manual

LSUM 048R6C 0166F EA YJ

## 6. Output terminal connection

The LS 48.6V / 166F Ultracapacitor Modules are designed to connect directly to a ring or a bus bar. The positive and negative terminals have each hole for the screw. The positive terminal threaded size is M8 and negative terminal is M10. Wave washers are required to ensure long term, reliable connections.

When tightening the terminal bolt, a torque of 20 N-m for the M8 bolt should be used.(30N-m for the M10 bolt) Because the modules have a very low ESR, total ESR will be affected by a ring lug, bus bar or torque. Therefore, it needs more attention to assemble the modules. And appropriate protection and sealing should be used on both module terminals to avoid shock hazards and corrosion.

# User Manual

LSUM 048R6C 0166F EA YJ

## 7. Output connector

- The output of connector is tabulated below.

Pin #	Temperature		Temperature Over voltage alarm		
	Pin out	Signal	Pin out	Signal	Max. current
1	TEMP	Pin1 or Pin2	TEMP	Pin1 or Pin2	-
2	TEMP	Pin2 or Pin1	TEMP	Pin2 or Pin1	-
3	Not used	-	Over Voltage Alarm	High-inactive Low-active	5mA
4	Not used	-	GND	-	-

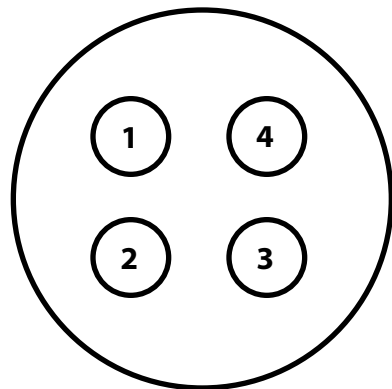

<Fig. 4> Monitoring connector



# User Manual

LSUM 048R6C 0166F EA YJ

## Temperature

- Pin 1, 2 is connected with a NTC thermistor for temperature monitoring. According to temperature variation in the module, the resistance of the thermistor is determined. The resistance measured through the thermistor relates to temperature according to the DK Sensor 10K@ 25°C resistance to temperature chart for the appendix I.
- Pin 3, 4 are not used.

## Temperature & Over voltage alarm

- Pin 1, 2 is connected with a NTC thermistor for temperature monitoring.
- Pin 4 is connected with monitoring connector output signals receiver circuit's ground. The output signals are isolated from the capacitor voltage and from chassis ground.
- When a cell in the module goes into over voltage condition, pin 3 has alarm signal. When every cell voltage is not over voltage state, the output of Pin 3 is high. If any cell in the module is exceeding 2.6V, the voltage balancing circuit becomes active and starts to discharge the cell. Nevertheless, if voltage keeps rising due to higher current, over voltage alarm become operating at 2.8V as output of Pin 3 becomes low. Then, user should stop charging. In order to use the signal, the user needs to attach a pull-up resistor(typically 1kΩ) to pin 3 and a 5V supply.

# User Manual

LSUM 048R6C 0166F EA YJ

## 8. Mounting

The modules should not be mounted in locations where they are directly exposed to the environment.

- You can easily adjust the Mounting Position through assemble the bracket.
- Bracket doesn't include the module.

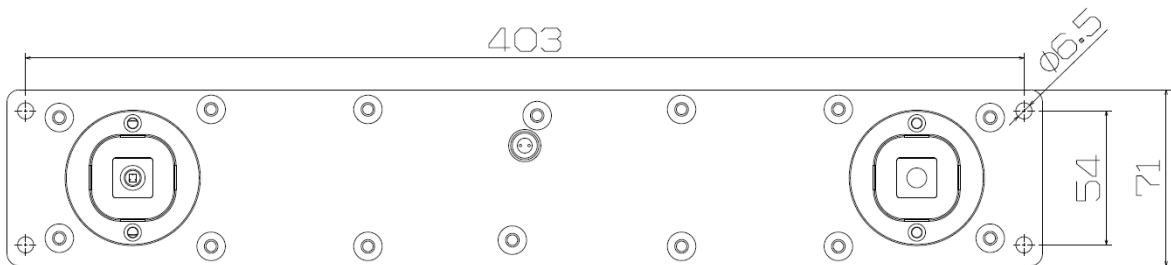

<Fig. 5> Bracket Positions

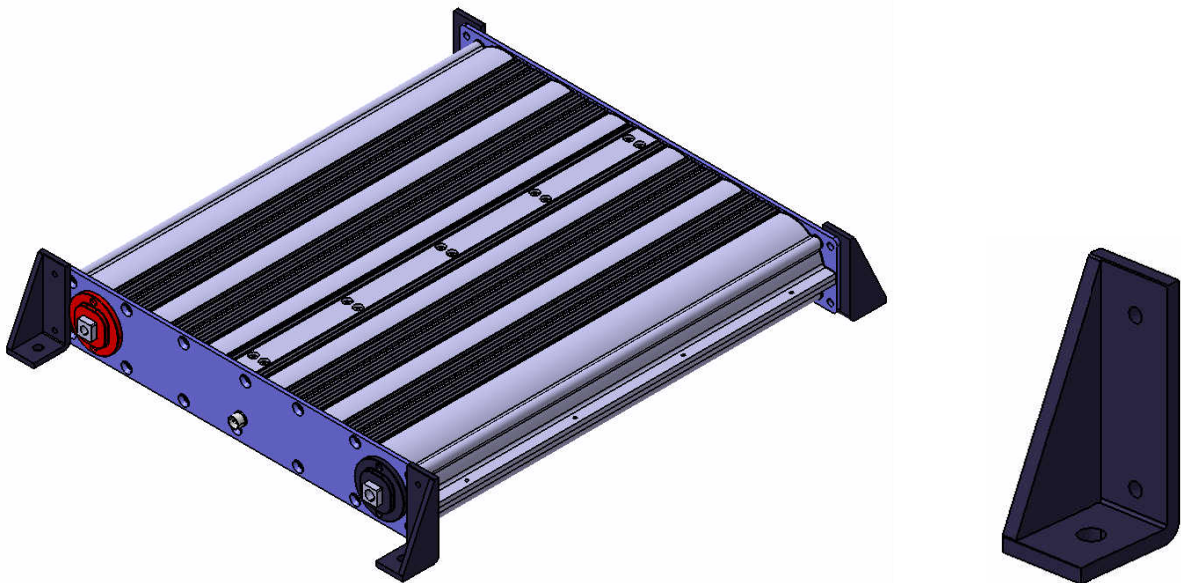

# User Manual

LSUM 048R6C 0166F EA YJ

## 9. Maintenance

### Power Rating

The rated voltage of the module is max 48.6V. If the applied voltage is over 48.6V, charging the module should be stopped. And the allowable low voltage level of the module depends on the user's requirements, but full discharging to 0V does not affect the module performance.

### Temperature

The module has its optimal operating temperature range of -40 to 65. Over 70°C, charging and discharging should be stopped to expect its performance and life cycle.

### Do not expose to direct sunlight

For installation do not make the module expose to direct sunlight due to temperature increase inside the module.

### Maintenance

The module has its expected life cycle over 10years at rated voltage and +25°C. However the life cycle of the module may be decreased in high temperature condition or over voltage charging.

If following abnormal module performances are detected, operation should be stopped and checking the electrical & mechanical connections is recommended.

- Monitoring high temperature in normal operating conditions
- Internal resistance increase or initial voltage drop increase
- Deformation of the module case

# User Manual

LSUM 048R6C 0166F EA YJ

## 10. Contact Information

LS Ultracapacitor

LS Mtron

6F, LS Mtron Hi-Tech Center, 39, LS-Ro, 116beon-gil, Dongan-gu, Anyang-si,  
Gyeonggi-do 431-831, Korea

Tel. +82-31-8045-9579

Fax. +82-31-8045-9544

E-mail. [ultracapacitor@lsmtron.com](mailto:ultracapacitor@lsmtron.com)

# User Manual

## LSUM 048R6C 0166F EA YJ

### Appendix I

T(°C)	Rmin(kΩ)	Rcent(kΩ)	Rmax(kΩ)	DR(%)	DT(°C)
-40	332.8	348.4	364.6	4.65%	0.67
-39	311.2	325.5	340.4	4.58%	0.66
-38	291.2	304.3	318.0	4.51%	0.66
-37	272.5	284.7	297.3	4.44%	0.65
-36	255.2	266.4	278.0	4.37%	0.65
-35	239.1	249.4	260.2	4.30%	0.64
-34	224.2	233.7	243.6	4.23%	0.64
-33	210.2	219.0	228.1	4.17%	0.63
-32	197.3	205.4	213.8	4.10%	0.63
-31	185.2	192.7	200.4	4.03%	0.62
-30	173.9	180.8	188.0	3.97%	0.61
-29	163.4	169.8	176.4	3.90%	0.61
-28	153.6	159.5	165.6	3.84%	0.60
-27	144.5	149.9	155.6	3.77%	0.60
-26	135.9	141.0	146.2	3.71%	0.59
-25	127.9	132.6	137.5	3.64%	0.59
-24	120.5	124.8	129.3	3.58%	0.58
-23	113.5	117.5	121.6	3.52%	0.58
-22	107.0	110.7	114.5	3.46%	0.57
-21	100.9	104.3	107.8	3.40%	0.56
-20	95.15	98.33	101.6	3.34%	0.56
-19	89.79	92.74	95.77	3.27%	0.55
-18	84.76	87.50	90.31	3.21%	0.55
-17	80.05	82.59	85.19	3.16%	0.54
-16	75.63	77.98	80.40	3.10%	0.53
-15	71.49	73.66	75.90	3.04%	0.53
-14	67.59	69.61	71.69	2.98%	0.52
-13	63.94	65.81	67.73	2.92%	0.51
-12	60.50	62.24	64.02	2.86%	0.51
-11	57.27	58.88	60.53	2.81%	0.50
-10	54.23	55.73	57.26	2.75%	0.49
-9	51.37	52.76	54.18	2.69%	0.49
-8	48.68	49.97	51.29	2.64%	0.48
-7	46.15	47.35	48.57	2.58%	0.47
-6	43.77	44.88	46.01	2.53%	0.47
-5	41.52	42.55	43.60	2.47%	0.46
-4	39.40	40.36	41.34	2.42%	0.45
-3	37.41	38.29	39.20	2.37%	0.45
-2	35.52	36.35	37.19	2.31%	0.44

# User Manual

## LSUM 048R6C 0166F EA YJ

T(℃)	Rmin(kΩ)	Rcent(kΩ)	Rmax(kΩ)	DR(%)	DT(℃)
-1	33.74	34.51	35.29	2.26%	0.43
0	32.07	32.78	33.50	2.21%	0.43
1	30.48	31.14	31.81	2.15%	0.42
2	28.99	29.60	30.22	2.10%	0.41
3	27.57	28.14	28.72	2.05%	0.40
4	26.24	26.78	27.30	2.00%	0.40
5	24.97	25.48	25.98	1.95%	0.39
6	23.78	24.23	24.69	1.90%	0.38
7	22.64	23.07	23.49	1.85%	0.37
8	21.57	21.98	22.38	1.80%	0.37
9	20.58	20.92	21.29	1.75%	0.36
10	19.60	19.94	20.27	1.70%	0.35
11	18.69	19.00	19.31	1.65%	0.34
12	17.83	18.12	18.41	1.60%	0.34
13	17.01	17.28	17.54	1.55%	0.33
14	16.24	16.48	16.73	1.51%	0.32
15	15.50	15.73	15.98	1.46%	0.31
16	14.80	15.01	15.22	1.41%	0.30
17	14.14	14.33	14.53	1.36%	0.30
18	13.51	13.69	13.87	1.32%	0.29
19	12.91	13.08	13.24	1.27%	0.28
20	12.35	12.50	12.65	1.23%	0.27
21	11.81	11.95	12.09	1.18%	0.26
22	11.29	11.42	11.55	1.13%	0.25
23	10.81	10.92	11.04	1.09%	0.24
24	10.34	10.45	10.56	1.04%	0.24
25	9.900	10.00	10.10	1.00%	0.23
26	9.472	9.572	9.671	1.04%	0.24
27	9.064	9.164	9.264	1.09%	0.25
28	8.677	8.778	8.875	1.13%	0.26
29	8.308	8.408	8.505	1.18%	0.27
30	7.957	8.054	8.153	1.22%	0.29
31	7.622	7.719	7.817	1.26%	0.30
32	7.304	7.400	7.498	1.30%	0.31
33	7.000	7.095	7.191	1.35%	0.32
34	6.711	6.805	6.900	1.39%	0.33
35	6.438	6.528	6.622	1.43%	0.35
36	6.173	6.265	6.357	1.47%	0.36
37	5.922	6.013	6.104	1.52%	0.37
38	5.683	5.772	5.862	1.56%	0.38
39	5.455	5.543	5.631	1.60%	0.40
40	5.237	5.324	5.411	1.64%	0.41
41	5.030	5.114	5.200	1.68%	0.42
42	4.831	4.915	4.999	1.72%	0.44
43	4.641	4.724	4.807	1.76%	0.45
44	4.460	4.541	4.623	1.80%	0.46

# User Manual

## LSUM 048R6C 0166F EA YJ

T(°C)	Rmin(kΩ)	Rcent(kΩ)	Rmax(kΩ)	DR(%)	DT(°C)
45	4.287	4.367	4.447	1.84%	0.47
46	4.122	4.200	4.279	1.88%	0.49
47	3.964	4.040	4.118	1.92%	0.50
48	3.812	3.887	3.964	1.96%	0.51
49	3.668	3.741	3.816	2.00%	0.53
50	3.529	3.601	3.675	2.04%	0.54
51	3.397	3.468	3.540	2.08%	0.55
52	3.270	3.339	3.410	2.11%	0.57
53	3.149	3.217	3.286	2.15%	0.58
54	3.032	3.099	3.167	2.19%	0.59
55	2.921	2.986	3.053	2.23%	0.61
56	2.814	2.878	2.944	2.27%	0.62
57	2.712	2.775	2.839	2.30%	0.64
58	2.614	2.675	2.738	2.34%	0.65
59	2.520	2.580	2.642	2.38%	0.66
60	2.430	2.489	2.549	2.41%	0.68
61	2.344	2.401	2.460	2.45%	0.69
62	2.261	2.317	2.375	2.49%	0.71
63	2.181	2.237	2.293	2.52%	0.72
64	2.105	2.159	2.214	2.56%	0.74
65	2.032	2.085	2.139	2.60%	0.75
66	1.962	2.013	2.066	2.63%	0.77
67	1.894	1.945	1.997	2.67%	0.78
68	1.829	1.879	1.930	2.70%	0.80
69	1.767	1.815	1.865	2.74%	0.81
70	1.707	1.755	1.803	2.77%	0.83
71	1.650	1.696	1.744	2.81%	0.84
72	1.594	1.640	1.686	2.84%	0.86
73	1.541	1.586	1.631	2.88%	0.87
74	1.490	1.534	1.578	2.91%	0.89
75	1.441	1.483	1.527	2.95%	0.90
76	1.394	1.435	1.478	2.98%	0.92
77	1.348	1.389	1.431	3.01%	0.93
78	1.304	1.344	1.385	3.05%	0.95
79	1.262	1.301	1.341	3.08%	0.96
80	1.222	1.260	1.299	3.11%	0.98
81	1.183	1.220	1.258	3.15%	1.00
82	1.145	1.181	1.219	3.18%	1.01
83	1.109	1.144	1.181	3.21%	1.03
84	1.074	1.109	1.145	3.25%	1.04
85	1.040	1.074	1.110	3.28%	1.06
86	1.008	1.041	1.076	3.31%	1.08
87	0.9765	1.009	1.043	3.34%	1.09
88	0.9464	0.9785	1.011	3.38%	1.11
89	0.9174	0.9488	0.9811	3.41%	1.12
90	0.8894	0.9201	0.9517	3.44%	1.14

# User Manual

LSUM 048R6C 0166F EA YJ

## Appendix II

### Drawing

